

VIVAX[®] HBC

Central locking plastic castors
for hospital & care beds

Made in Germany



VIVAX® HBC

Central locking plastic castor series
for hospital & care beds

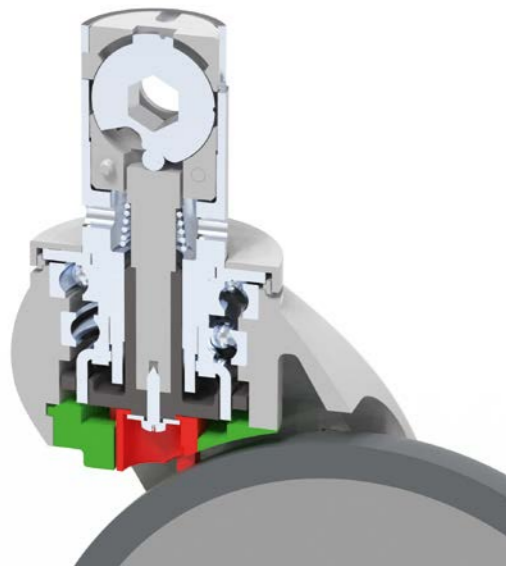

Two large sized ball bearings give the VIVAX® HBC high resistance to load-bearing and, above all, impact loads, including a test with 20mm high obstacles with full 130 kg load without failing. A big plus for your safety.

The direction determination is directly connected to the castor fork by the shaping when actuated, which also make it strong in use.

A new stop system offers additional safety against overloading and ensures a long service life. The plastic spindle with a novel transmission of operating forces (patent pending) ensures a permanent perfect funktion.

Modern high-performance plastic protect the environment, but offers the same performance as steel.

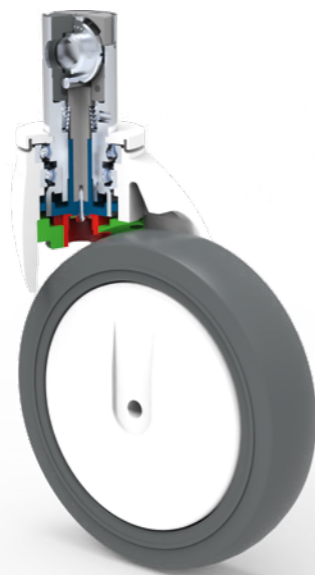

The cavities which are important for the function of the locking mechanism are tightly sealed. Foreign objects and dirt cannot penetrate. The remaining area is easily accessible for cleaning and spray disinfection, a plus for hygiene and functional safety.

VIVAX® HBC Castor Series Made in Germany

THE ALTERNATIVE TO METAL CASTORS

Whether cleaning machines, shopping trolleys or standardized castors for the medical and gastronomic sector, the selection of the right castor is a difficult matter. Material, bearings, surface and wheel diameter influence the individual properties. Floor conditions, cleaning properties, durability and resilience – each application is always meaning other requirements to the castors.

STRENGTH, SWIVEL & RUNNING BEHAVIOR OR THE DESIGN: PLASTIC CASTORS WILL MASTER THESE REQUIREMENTS!

HIGH STRENGTH

Glass fibre reinforced polyamide ensures high strength and almost unlimited stability in the VIVAX® HBC castors. Even at high temperatures, it makes the castors durable against all detergents and disinfectants, alkalis, diluted acids, oils, lubricants, alcohols and gasoline known today. This „built-in“ corrosion protection requires no additional processing during production. Therefore the VIVAX® HBC castor is in contrast to ordinary metal castors significantly more environmentally friendly.

PERFECT SWIVEL PROPERTIES

Continuously optimal swivel properties are indispensable, especially for trolleys that are used permanently. With the VIVAX® HBC castor, two precision ball bearings in the fork head guarantee many years of use with unrestricted functionality. The good damping properties and the low weight also contribute to the comfortable running behavior.

ATTRACTIVE DESIGN

Not just a matter of taste: Especially in areas with public traffic such as gastronomy or healthcare, the attractive design of the castors is very important. It's not just about a good looking shape or color, but also about a „well-groomed“ appearance. Castors with scratches look unkempt and unhygienic. Solid-colored plastic castors are of course not immune to scratches, but these are far less visible than on metal castors.

EASY CUSTOMIZATION

The available color palette is very extensive. If a special color is not available, a corresponding coating of the castors can be easily and permanently realised. Furthermore individual imprints such as your logo are possible to complete your distinctive corporate identity.

STANDARD-COMPLIANT DESIGN

With all design requirements, compliance with certain standards for castors and brakes is an indispensable criterion of our work.

QUALITY MADE IN GERMANY

The VIVAX® HBC castors are manufactured in our own factory according to your individual demand. For you, this means excellent quality and fast, uncomplicated delivery.

wheel series for **VIVAX® HBC** Castors

The right wheel for every application. All wheels are also available electrically conductive and with stainless steel bearings, of course also in combination.

If you want plain bearings or roller bearings for special applications, please call us.



Performa

A very special material, developed for particularly high demands on wheels for your castors. In a unique way, rolling comfort and load capacity are combined with good values for rolling, starting and swivel resistance. Low abrasion values are another feature of the material.

We have also made this material available for the field of apparatus & medical castors and developed a new wheel family. With these wheels, the full potential of the VIVAX® housing series is exploited and now offers a load capacity of 130 kg even with soft wheels. It is a peak value in reference to apparatus & medical castors. Furthermore outstanding design is combined with high load capacity. Performa wheels are available in different versions, all with ball bearings and thread guards.



Article Code 1C
TPE Tread
Non-oiling,
87° Shore (A),
Ball Bearing,
Thread Guards

∅	article-no.	load capacity	wheel width
125 mm	51C	100 kg	32 mm
150 mm	61C	100 kg	32 mm



Article Code 1CA
Conductive < 10⁴Ω
TPE Tread
Non-oiling,
87° Shore (A)
Ball Bearing,
Thread Guards

∅	article-no.	load capacity	wheel width
125 mm	51CA	100 kg	32 mm
150 mm	61CA	100 kg	32 mm



Article Code 4C
Polyurethane Tread
95° Shore (A),
Ball Bearing,
Thread Guards

∅	article-no.	load capacity	wheel width
125 mm	54C	130 kg	32 mm
150 mm	64C	130 kg	32 mm



Article Code 4CA
Conductive < 10⁴Ω
Polyurethane Tread,
95° Shore (A),
Ball Bearing,
Thread Guards

∅	article-no.	load capacity	wheel width
125 mm	54CA	130 kg	32 mm
150 mm	64CA	130 kg	32 mm



Article Code 7C
Performa Tread 65°
Shore (A),
Ball Bearing,
Thread Guards

∅	article-no.	load capacity	wheel width
125 mm	57C	130 kg	32 mm
150 mm	67C	130 kg	32 mm



Article Code 7CA
Conductive < 10⁴Ω
Performa Tread
65° Shore (A),
Ball Bearing,
Thread Guards

∅	article-no.	load capacity	wheel width
125 mm	57CA	130 kg	32 mm
150 mm	67CA	130 kg	32 mm



Construction of wheel:
ball bearing, sealed

VIVAX® HBC Cross section

Wheels with stainless steel bearings available. Please use Article Code: „...CN“!

PLEASE NOTE:
If you want to order single wheels, please do not use above numbers. Please contact us for clarification!

Castor series

VIVAX® HBC

combine swivel bearing housings, wheels & fittings individually and tailor-made for your requirements.



51C	54C	57C
61C	64C	67C



Castor structure:

High-performance plastic housing with steel stem and two ball bearings in swivel head for high load capacities.



Swivel castor with central total brake

KH2Q

Swivel castor with central total and directional brake

KH2R

KH2R-61C-Z985



Z4351

Fittings Stem galvanized

stem \varnothing 27,8x100 mm, standard hole M8x19 mm, switching shaft distance 78.5 mm, measured from the tube seat

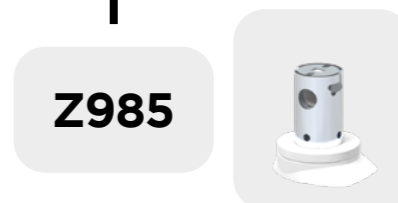
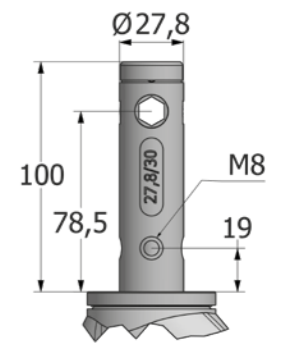

Z985

stem \varnothing 32x50 mm, standard hole M6x7 mm, switching shaft distance 34 mm, measured from the tube seat

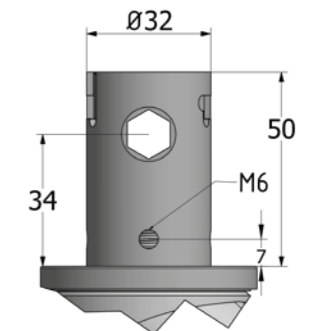

VIVAX® HBC Cross section

Castor series **VIVAX® HBC**

- technical overview:
- construction
 - bearing types
 - dimensions

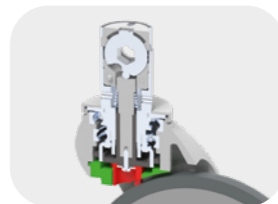

Construction of swivel head: Two ball bearings, sealed



Construction of wheel: Ball bearing, sealed

VIVAX® HBC Technical Data



125	109	46	164
150	121	46	189

Castor series conductive <math><10^4\Omega</math>

VIVAX® HBC

combine swivel bearing housings, wheels & fittings individually and tailor-made for your requirements.



51CA	54CA	57CA
61CA	64CA	67CA

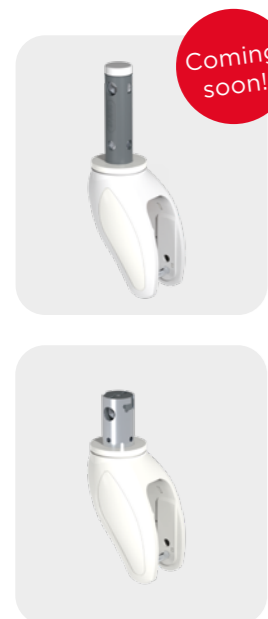

Castor structure:

High-performance plastic housing with steel stem and two ball bearings in swivel head for high load capacities.

Swivel castor with central total brake

KH2Q

Swivel castor with central total and directional brake

KH2R

KH2R-61CA-Z985



Z4351

Fittings Stem galvanized

stem \varnothing 27,8x100 mm, standard hole M8x19 mm, switching shaft distance 78.5 mm, measured from the tube seat

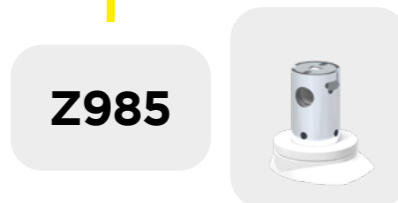
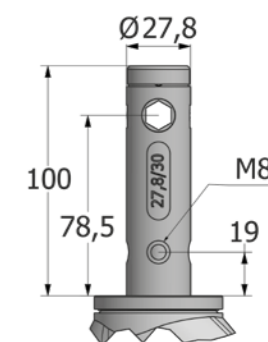

Z985

stem \varnothing 32x50 mm, standard hole M6x7 mm, switching shaft distance 34 mm, measured from the tube seat

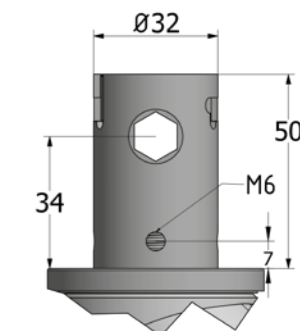

VIVAX® HBC Cross section

Castor series **VIVAX® HBC**

- technical overview:
- construction
 - bearing types
 - dimensions

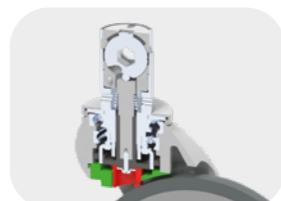

Construction of swivel head:
Two ball bearings, sealed



Construction of wheel:
Ball bearing, sealed

VIVAX® HBC Technical Data

125	109	46	164
150	121	46	189

VIVAX® HBC
Central Locking
Plastic Castor Series

The best solution for your hospital & care beds.





Rolling

at the speed of life



Colson Rollen GmbH
Industriestraße 8
D-42499 Hückeswagen

Tel.: +49 2192 9368-0
Fax: +49 2192 9368-477

Web: www.colson-rollen.com
E-Mail: info@colson-rollen.com